



**BARRIER
TERMINAL BLOCK**

TYPE BTB450



SPECIFICATIONS

WIRE ENTRANCE:Parallel to PCB	MAX. TORQUE:5 lb-in.
CENTER SPACING:6.35mm / 0.25 in	PRESSURE PLATE:.....Steel, Ni Plated
WIRE RANGE:18--22 AWG	SCREW: M3, Steel, Ni Plated
ELECTRICAL RATING:300V, 10A	TERMINAL BODY:Brass, Tin Plated
BREAKDOWN VOLTAGE:4,000V	OPERATING:-40°C to +120°C
MOLDING:Thermoplastic, UL94, V-0 Self Extinguishing	MAX. SOLDERING:260°C , +500°F for 5 seconds

MECHANICAL DIMENSIONS

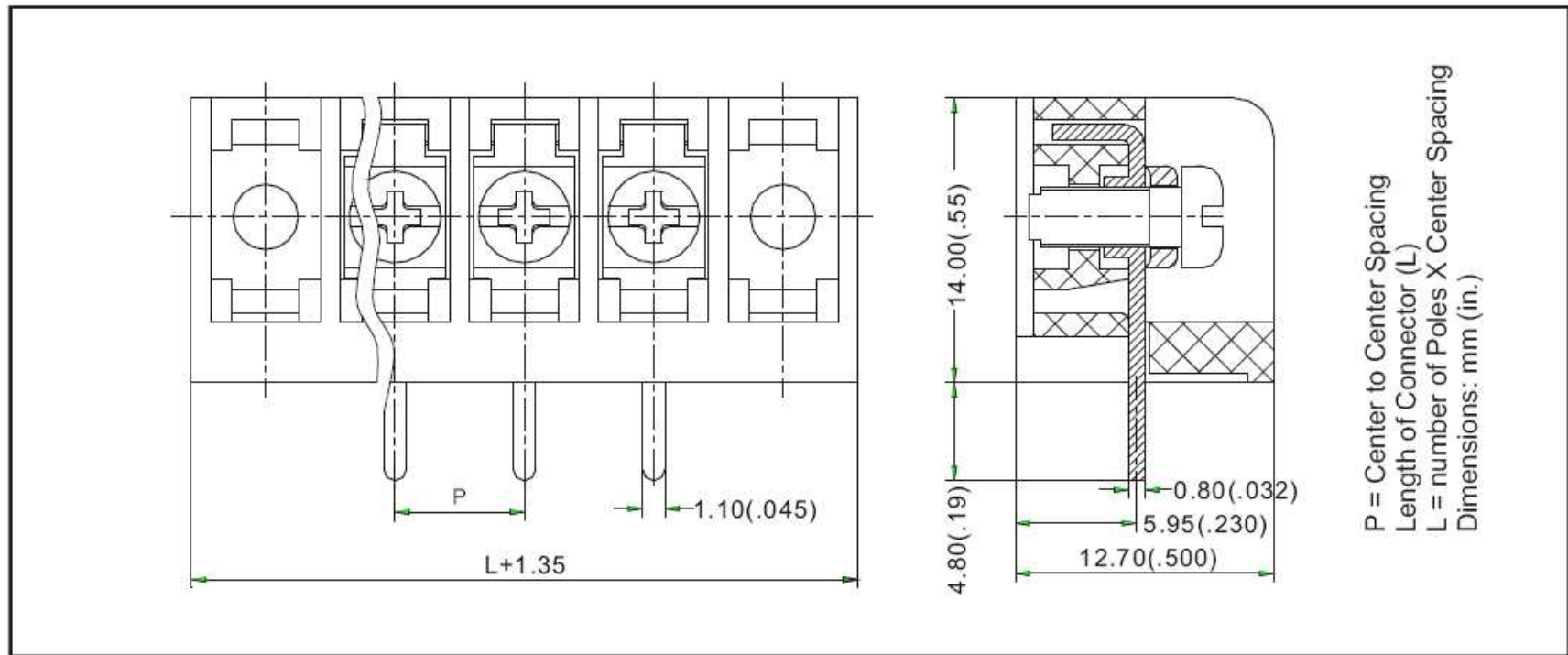

ORDERING INFORMATION

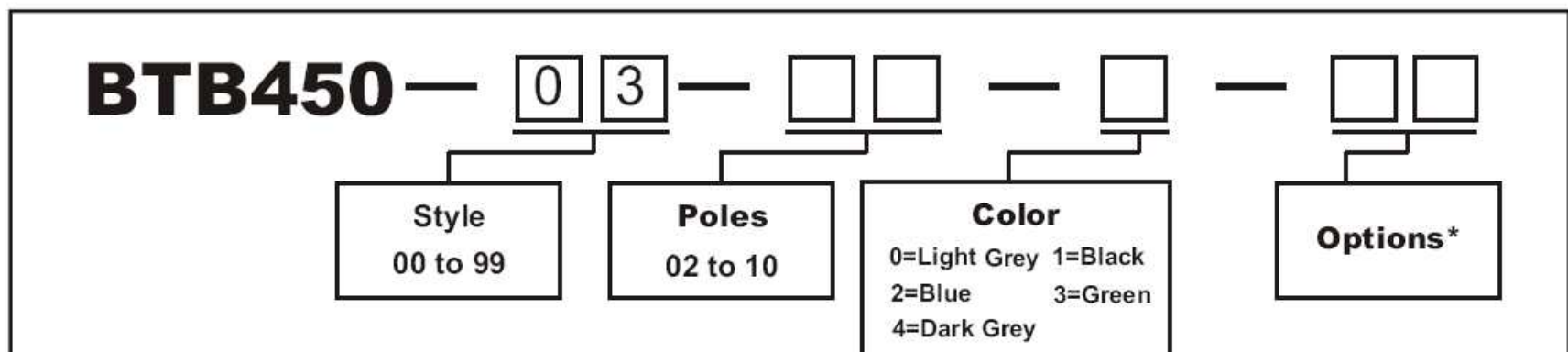

Options*: M1~M9, For Customer Modification (Please provide sketch).
 If more than one option is required, please separate each option with a dash (-).